

REVISION	DESCRIPTION	DATE	DESIGN	APPROVED
A	DRW CREATED	5.2.2019	MAM <i>[Signature]</i>	VPA <i>[Signature]</i>

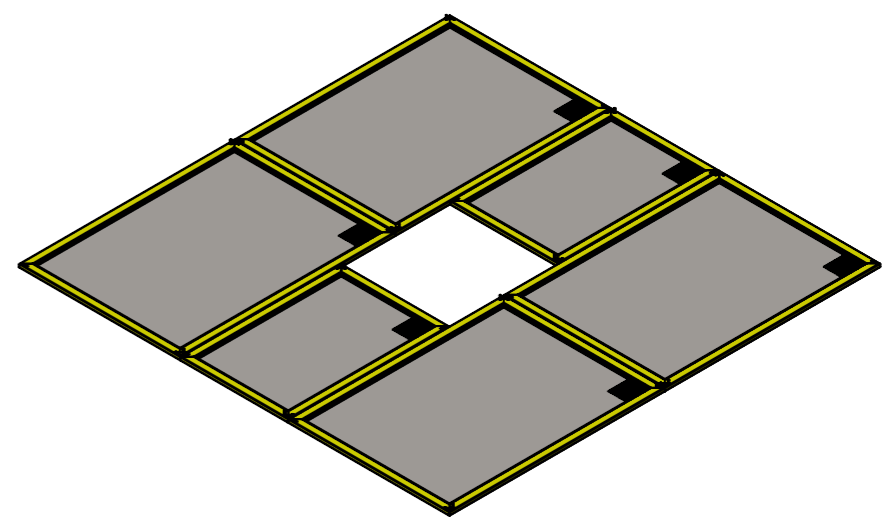
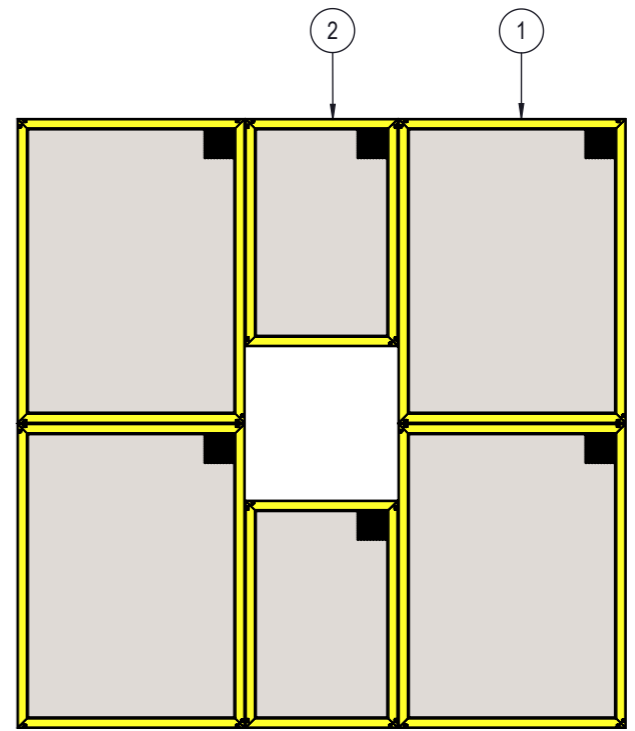
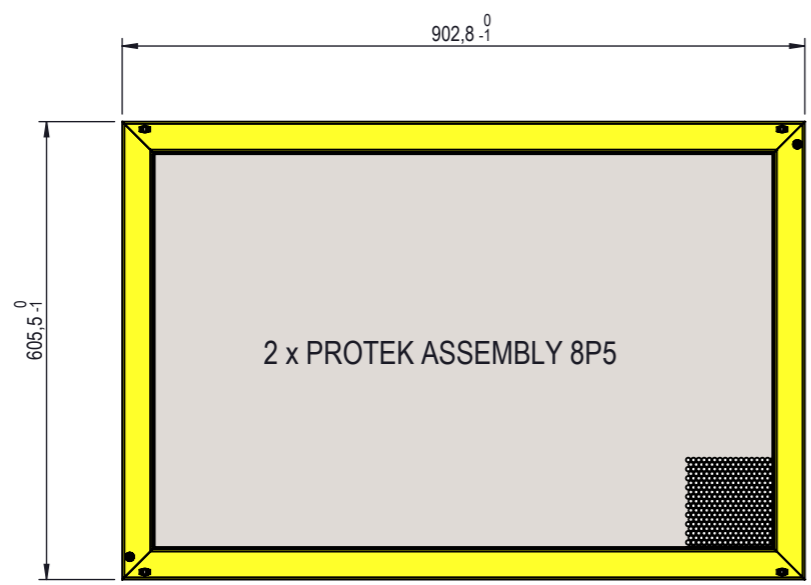
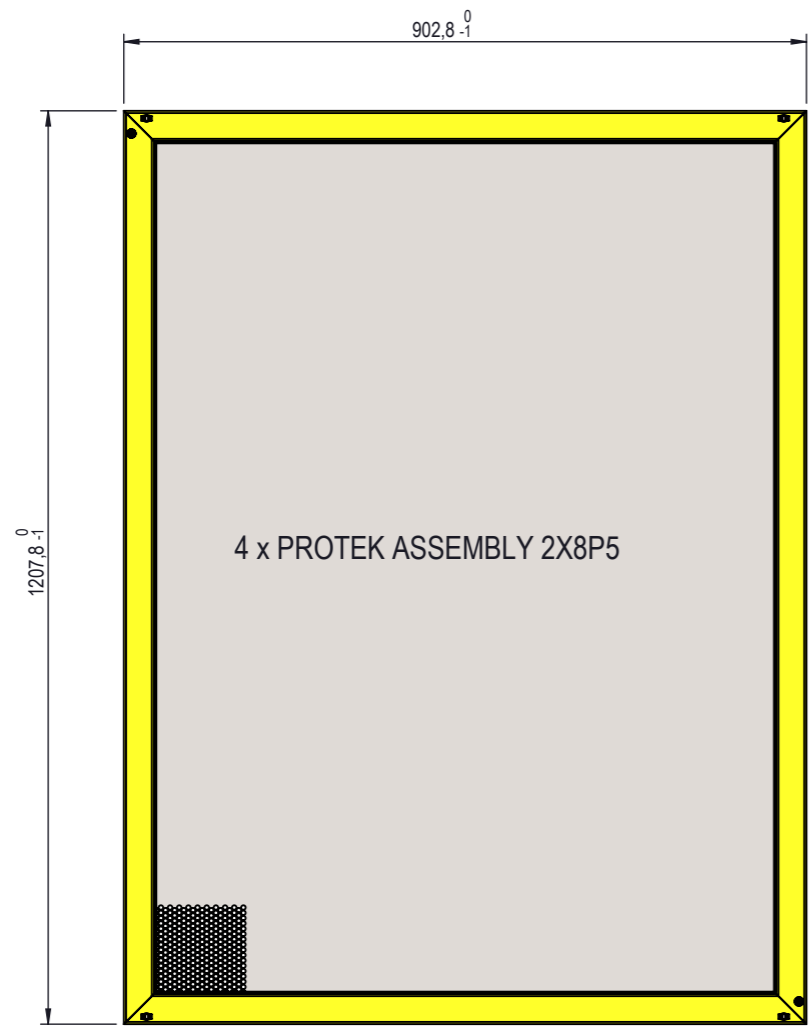

Stainless Steel 1.4307 (304L)
pickled - glass blasted

ITEM	DRAWING NUMBER	DESCRIPTION	QTY.	CAMHOSP PAINTED MATERIAL	CAMHOSP PAINTED FINISH	CAMHOSP SS 304L MATERIAL	CAMHOSP SS 304L FINISH
1	5526-3011-500	PROTEK ASSEMBLY 2X8P5	4	SS304 EN 10086-3 X5CrNi 1810 - (1.4301)	Pickled passivated	SS304 EN 10086-3 X5CrNi 1810 - (1.4301)	Pickled passivated
2	5526-3540-500	PROTEK ASSEMBLY 8P5	2	SS304 EN 10086-3 X5CrNi 1810 - (1.4301)	Pickled passivated	SS304 EN 10086-3 X5CrNi 1810 - (1.4301)	Pickled passivated

Approved
 Approved as noted
 Revise and Resubmit

NAME: _____ SIGNATURE: _____
 COMPANY: _____ DATE: _____

DESCRIPTION: Finishing Panels Kit - CamHosp 2
Protek Type 3

PROJECT: -

DRAWING REF.: 5526-3000-500

LAST REVISION: 5.2.2019

WEIGHT: 77.67 kg

SHEET: 1/1

SIZE: A3

SCALE: 1:10

NB: The copyright of this drawing remains with Camfil.
 Contents must not be used, copied or disclosed to
 third parties without prior written consent.
 All rights reserved.